

ESOTERIC

Network DAC/Preamp **N-05XD**

Class A Stereo Power Amplifier **S-05**

Minimalist High End Style





Minimalist High End Style

Welcome to first class.

This sleek stem, consisting of the N-05XD
and the S-05 is simple, yet versatile.

All you have to do is carefully choose
a pair of speakers, and you will be set for life.

"I want to enjoy high-end audio in a minimalist way. However, I do not want to compromise on sound quality" – The combination of N-05XD and S-05 is a new concept audio system developed by Esoteric for such customers.

The N-05XD is an innovative network DAC preamplifier that incorporates the essence of what is typical of Esoteric branded products. The N-05XD is equipped with a Master Sound Discrete DAC that incorporates the development results of the brand's top model, the Grandioso D1X, and a fully balanced and dual mono preamp that incorporates the development results of the Grandioso C1X, the top model in the preamplifier range. In addition, the N-05XD is equipped with a headphone amplifier suitable for personal use.

Paired with the N-05XD is the S-05, a Class A stereo amplifier that incorporates the key technologies of the Grandioso M1X. The output power of the S-05 is 30 watts per channel into 8 ohms, class A. The S-05 can be used in normal stereo mode, in BLT mode or in bi-amp mode using two S-05s. We have designed this product with a strong focus on the 'unique timbre that only the S-05 can express'.

In designing this system, rather than adding unnecessary functions, we have reduced the number of functions to the minimum necessary for an integrated system, and then thoroughly refined the sound quality using flagship technology. The resulting N-05XD/S-05 combination system is a "truly valuable" audio system with minimalist styling and a super-high level of sound quality worthy of the Esoteric brand.



Reproducing the full sound quality of the original masters.

The N-05XD represents a new frontier in network DAC/preamps.



As Esoteric's first-ever network DAC/preamp, the N-05XD was specifically designed to deliver superior sound quality from the smallest system configurations combining your favorite power amplifier, speakers, and headphones. Integrating fully balanced circuitry directly derived from Esoteric's flagship series, the N-05XD's network engine is equipped with a pure, dedicated linear power supply and an in-house designed discrete DAC that ensures that its preamplifier and headphone amplifier are capable of clearly reproducing the full sound of a recording's original master. No longer must superior sound quality be sacrificed in the pursuit of a simplified high-end audio system.

Key Features

- Master Sound Discrete DAC for full reproduction of vibrancy and energy of music
- Uniquely developed 64bit/512Fs-compatible Delta-Sigma modulator and FPGA program
- Network engine with dedicated linear power supply that follows N-01XD
- Compatible with a wide selection of audio codecs and streaming services (Tidal, Qobuz, Roon, Spotify, MQA)
- Fully balanced dual mono preamplifier with total of 4 (left/right and positive/negative) independent circuits as proven in the C series
- Esoteric's proprietary current signal transmission, "ES-Link Analog"
- Fully balanced dual mono headphone amplifier (balanced output: 1,500mW/32Ω)
- Total 2 headphone outputs (4-pin XLR balanced/6.3mm stereo unbalanced)
- Can be configured as a standalone DAC, by deactivating preamp function
- AV through out function, and network off function
- Broadband digital transmission ES-Link (XLR x 1) input for connecting SACD transport
- Built-in Bluetooth® receiver
- Clock sync function



Network DAC/Preamp **N-05XD**

Master Sound Discrete DAC

Faithful Reproduction of the Liveliness and Energy of Music

Esoteric's primary goal in the creation of the N-05XD Network DAC/Preamp was to assemble a careful selection of rigorously tested discrete components into a complete circuit that could perfectly reproduce all the dynamics and energy of recorded music, something simply unattainable using ordinary integrated chips. Esoteric's top engineering teams put their pride on the line to design and produce a quality of sound that can only be experienced by way of our Master Sound Discrete DAC.



Luxurious Materials and Powerful Current Output Capacity

The N-05XD's Master Sound Discrete DAC is the most revolutionary two-channel stereo DAC circuit in Esoteric history, and is an extension of the design philosophy of the Grandioso D1X Monoblock DAC, with a simplified circuit that consists of 16 separate elements per channel.

The signal processing algorithm is our proprietary FPGA* based, and the Delta-Sigma ($\Delta\Sigma$) modulators are independent for each DSD and PCM processing, and support 64-bit/512Fs sampling frequency.

* FPGA: Field-Programmable Gate Array

Network Engine with Dedicated Linear Power Supply

As a source component, the N-05XD is equipped with a dedicated high-end network audio engine that supports DSD 22.5MHz playback. The key component in this design is its dedicated linear power supply. With a component configuration equivalent in scale to that of Esoteric's top-of-the-line N-01XD, the N-05XD's large toroidal transformers, conventional large capacitors, Schottky barrier diodes, and high-end super capacitors — which feature a whopping 2,333,333 μ F in total capacitance — and forgoing the use of any noisy switching elements, the N-05XD realizes a singularly impressive sound brimming with an analog-like sense of reality.

Compatible with a Wide Selection of Audio Codecs and Streaming Services



Esoteric Sound Stream

Esoteric Sound Stream is a streaming and network playback control app designed for use with both iOS (iPhones & iPads) and Android. Even inexperienced neophytes can operate this app with fully intuitive and stress-free ease.

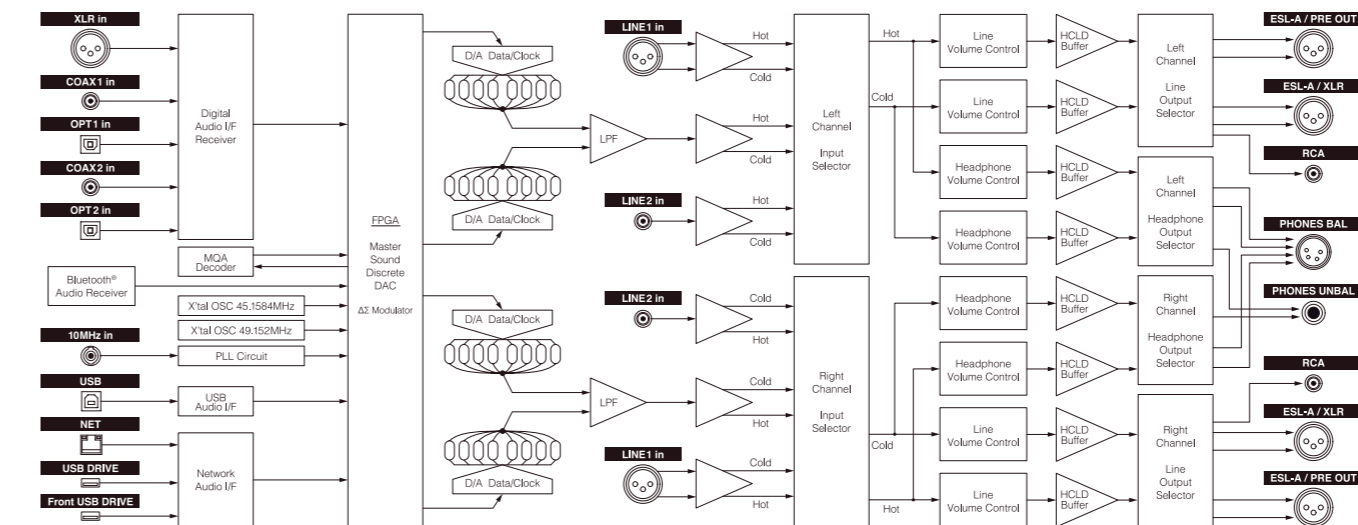



**The Heart of the System:
A Fully Balanced Dual Mono Preamplifier**

At the core of any audio system, the preamplifier circuitry plays the central determining factor in how sound is perceived. The N-05XD inherits the Grandioso line's high fidelity and superb musical expression, a compendium of both Esoteric's long-held philosophy and advanced technology, while further inheriting its esteemed pedigree. With its long-established fully balanced dual mono configuration, the preamplifier's dynamic yet delicate sound transcends the boundaries of playback quality, and even goes so far as to delineate the sensibilities of both the performers and the sound engineer.

Installed in the N-05XD's preamplifier section, the Esoteric-QVCS* Attenuator system features a total of four collectively operated attenuator circuits that independently and electronically control the left and right audio channels and their positive and negative phases. This system helps maintain superb audio clarity, excellent channel separation and highly accurate phase characteristics. Additionally, the vastly shorter audio signal path helps minimize sound quality deterioration at both low and high volumes and allow the complete, unadulterated expression of musical passion.

Unique Esoteric-HCLD Output Buffer Circuitry

The N-05XD's Esoteric-HCLD output buffer circuit was designed in pursuit of the ultimate in current transmission capacity and speed, both of which are critically important factors in achieving the ultimate in analog output circuitry. The buffer's high-speed element features a slew rate—or response speed—of 2,000V/μs, allowing

it to reproduce with breathtaking clarity the full dynamism of the music being played.

The N-05XD also comes fully equipped with Esoteric's original Es-Link Analog transmission output. This advanced current transmission method takes advantage of the HCLD buffer circuit's high performance to deliver powerful, high-speed current supply capability that makes it possible to transmit the audio signal purely, powerfully, and completely unaffected by signal path impedance. This ideal analog audio transmission method maximizes the potential of the system when connected to compatible devices.

Fully Balanced Dual Mono Headphone Amplifier

Enjoy the uniquely blissful musical listening experience of high end audio by using the N-05XD in combination with your favorite pair of headphones. The N-05XD accommodates Esoteric's first full-scale fully balanced dual mono headphone amplifier, and two separate outputs: a balanced 4-pin XLR output jack and an unbalanced 6.3mm stereo audio jack. With its 1500mW (into a 32Ω load) of output power, this superlative headphone amplifier powerfully drives high impedance headphones with plenty of headroom to spare. For unbalanced output, the ground potential is actively driven to 0V so that any fluctuations of ground (earth) potential in each of the left and right channels do not affect the other, thus realizing eminently clear channel separation, uncompromising high performance, and superb musical expressiveness.

The Ultimate Versatility

The N-05XD can be connected to an external preamp for operation as a standalone digital source or DAC when switched to fixed line level output. Likewise, network function can be completely turned off when not use. The N-05XD also comes with the ES-Link*, Bluetooth® connection, external clock input, and AV pass through output that allows it to be used as a front channel preamp in a surround sound AV speaker system.

*The ES-Link is Esoteric's original wideband digital interface, supporting a single XLR cable connection with Super Audio CD/CD transports/players.

Mechanical Perfection

To achieve the one and only design goal of "reproducing the master sound," the N-05XD/S-05 chassis optimally controls all vibrations that affect the sound quality. The mechanical engineering is like that of a sports car, with the balance between rigidity and flexibility pushed to the limit. The sleek and clean form of the chassis is a testament to its high degree of perfection. For example, the enclosure, which requires rigidity, makes extensive use of aluminum blocks and is thoroughly non-resonant. On the other hand, the top panel, which needs to be free of vibration for an open sound, has a semi-floating structure, and the isolation feet have a special structure that reduces mechanical stress and enhances sound quality.

**Remote Control Features
Easy-Operation Buttons on Both Sides**

The N-05XD remote control's ergonomic aluminum body fits naturally in the hand, with buttons located on both sides of the unit for the easiest and most intuitive operation from the comfort of your listening position. In addition to offering straightforward control of preamplifier and network playback, this remote control can also be used to operate the Esoteric Super Audio CD player and transport.



Top

Bottom

Driving power, pure performance.

– Welcome to Class A world



An all-new stereo power amplifier, borrowing from the engineering techniques utilized in our flagship Grandioso M1X mono block. The new S-05 – a class-A power amplifier thoroughly focused on delivering all of music’s unique tonal qualities from a more compact stereo configuration, embracing the philosophy of the Grandioso M1X: “minimal circuitry – maximum output”.

Key Features

- Lavish material employment, simple and straight circuit design concept borrowed from the Grandioso M1X
- Finely detailed Class-A sound with super dynamics – an Esoteric’s signature tone
- Dual monaural construction in all stages including power supply circuit for better channel separation
- Esoteric’s proprietary current signal transmission, “ES-Link Analog” delivers music signal with exceptional high power and fidelity.
- Large bi-polar 3 parallel push/pull circuit that instantaneously responds to the music signal
- 940VA large EI-core power transformer that responds to dynamic current supply changes with high speed
- Large “Grandioso grade” custom capacitors on each channel (10,000 μ F x 4/ch)
- Balanced input amplifier for stable, noise-free signal transmission
- BTL / Bi-amp mode switch for dual amplifier configuration
- DC Trigger for sequential power on/off with the N-05XD
- Esoteric’s unique isolation feet and semi-floating top panel
- Unique shaped heat-sink to minimize the peak resonance of itself



Fidelity

With the flagship Grandioso C1X/M1X, Esoteric has challenged the limits of fidelity in pre-power transmission and opened up new horizons. Esoteric's unique current transmission "ES-Link Analog" is the ideal method for pre-power transmission, where signal levels are extremely low in actual use. This Grandioso technology has been carried over to the S-05. Compared to conventional voltage transmission, ES-Link Analog transmits approximately 100 times more current. Therefore, it is less susceptible to noise, and all the energy of the music is transmitted from the preamplifier to the power supply. In principle, this system does not affected by the the impedance of the connecting cables, so the output signal from the preamplifier and the input signal to the power amplifier matches exactly identical to each other.

ES-Link Analog – Esoteric's unique current transmission

ES-Link Analog is Esoteric's proprietary current transmission method. By connecting devices that support this method, it is possible to reproduce the sound as if it were being played directly from an analog console in a recording studio. The sonic signature of ES-Link Analog is powerful, live and dimensional. In conventional voltage transmission, the output impedance of the source device is low, and the input impedance of the target device is high. In other words, the current required for signal transmission tends to be kept low.

Also, due to the resistance component (impedance) of the transmission path (interconnect cable), the voltage of the transmitted signal is attenuated by the level calculated by Ohm's law (voltage = current × resistance) when delivered to the target device. Therefore, a longer the cable causes increased resistance which has significant affects on that signal.

In contrast, in current transmission, the output impedance of the source device is high and the input impedance of the input device is low, resulting in a "High out, Low in" circuit, and the current level is maintained higher during signal transmission than in voltage transmission, allowing a powerful audio signal delivery.

Also, in current transmission, the current level output from the source device always matches the one on the target device. Imagine using a hose to send water from a faucet to a bucket. As long as there are no holes in the hose, the same amount of water from the faucet will always flow to the bucket, regardless of the length of the hose.

Similarly, if the cable that serves as the transmission path is not divided into multiple paths, all current from the source device will be delivered to the target device, and the current values flowing will always be the same, even if the transmission path is longer. This advantage of accurate transmission of even the smallest signals is evident from the fact that current transmission is widely used in measuring instruments that measure precise signals.

Conventional voltage transmission impedance of the Esoteric products is designed several tens of ohms on out-going circuits and around 100k ohms on in-coming circuits. In contrast, the ES-Link Analog out-going/in-coming circuits are designed approximately 1kΩ on the out-going circuit, and 0Ω on the in-coming circuit.

If we focus on the current value that flows when transmitting audio signals, the current level of ES-Link Analog transmission when transmitting audio signals at the same level as normal voltage transmission is approximately 100 times higher than the current level flowing in voltage transmission. Consequently, the high current level allows for the full energy of the music to be delivered.

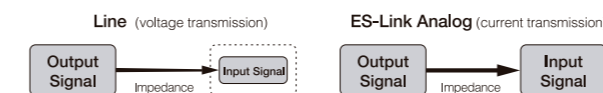



Dynamics

The S-05 is relatively compact, but its power supply is impressively huge. The power supply is the most important component in realizing a powerful and rich sound stage for the amplifier, which always requires a large current for Class A operation.

Thanks to Esoteric's unique power supply design, the musical expression of the S-05 is open and super dynamic.

Bare mount over-sized power transformer

The S-05 uses the largest transformer that can be installed (940VA EI core transformer). By using much larger transformer than the size required to fulfill its performance, the S-05 is able to follow dynamic changes in current supply extremely well, resulting in a dynamic and open sound. The reduction of transformer vibration results in the suppression of current flow. For this reason, the transformer is bare-mounted without a case.



Power rectification circuit with dual mono configuration

Unless the sound source is monaural, the left and right music signals are different. The power rectification circuits are not shared by the left and right channels, but are dual mono circuits, which avoid mutual interference between the left and right channels, resulting in clear channel separation and resolution.

Multiple block capacitors in parallel

In the S-05, the rectification system also incorporates the special attention that is unique to this model. The block capacitors are Grandioso grade high quality custom capacitors. Dual mono and parallel configuration of four 10,000 μ F capacitors per channel is used. The rectification operation is time-delayed in parallel to stabilize charge and release, thereby ensuring a large current supply required for Class A operation at all times. Therefore, it can faithfully and agilely follow the dramatic changes in the music signal and fully express its dynamism.

Low impedance design

Critical wiring from the primary side to the power supply section, drive stage, etc., is bolted with extra thick cables. The response of the power supply is maximized by ensuring a low impedance.

Vivid

Class A amplifiers have full sound texture with little distortion. This general Class A characteristic alone does not begin to describe the S-05's appeal. The S-05 is passionate, vivid like a direct heated triode amplifier. The transient response is extremely high speed backed up by the abundant idling current. It's powerful and dynamic.... Regardless of the amplification method, the S-05 is a new milestone in Class A amplifiers, a sincere pursuit of what an amplifier should be, and the culmination of Esoteric's commitment.

Less is More

This may seem a bit surprising considering the weighty appearance of the S-05. However, the signals are connected in the shortest possible path, and the circuitry is surprisingly simple. The clear sound quality is supported by the "subtractive

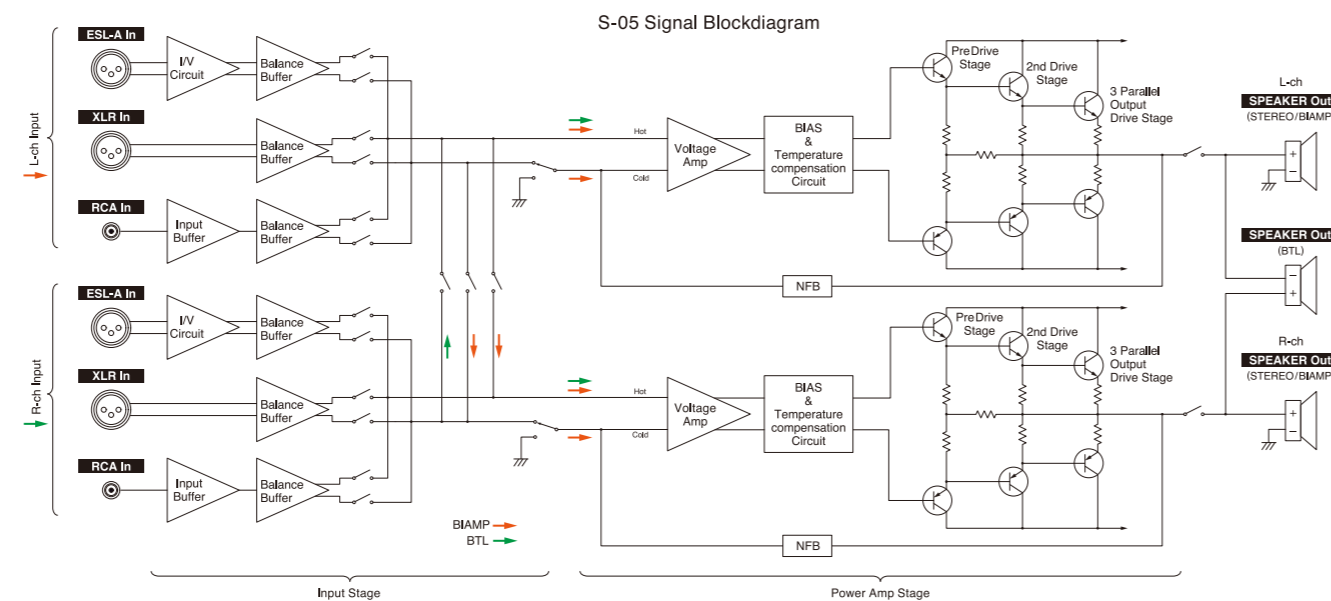

aesthetics," so to speak, created by the crystallization of advanced engineering. Class A amplifiers generate a lot of heat, so internal temperature stability is extremely important for optimum performance.

We optimized the position and circuitry of the temperature compensation circuit to stabilize the temperature of the entire amplifier block. This speeds up the stabilization of the idling current after power-on and allows the amplifier elements to operate at their best characteristics.

The phase compensation circuit is a simple one-pole configuration and the final stage is coil-less, minimizing negative feedback (NFB) and enhancing the dynamism of the music. The minimalist circuit philosophy allows the harmonics (overtones), which are the most important but easily lost in music, to be preserved and rendered in an expressive manner.

Depth

While the circuitry is simple, the S-05 has been thoroughly implemented in a dual monaural configuration from the input stage to the final stage through the use of material resources, eliminating any compromise in the quality of reproduction.

The components are of the highest class, with a board pattern using 105 μm thick copper foil, and ultra-thick gauge cables with connector connections eliminated as much as possible, all with the boldness that is typical of power amplifiers. The eight bass bars in the drive stage are made of luxurious 1.0mm thick high-purity OFC material, and MOS FET switches without mechanical contacts are used in the speaker output section.

With reduced internal impedance, even woofers with large diameters are powerfully gripped, and the drive power effortlessly reaches the limit point of the low frequency range.

Texture

The S-05 is not only powerful, but also delicately renders the gradations that connect climax and silence. The signal is received by a newly designed balanced amplifier independent of each input system and transmitted in a balanced configuration up to the amplification stage to ensure noise-free, stable amplification. FET switches with minimal tonal coloration are used for all switches in the audio signal path. Selected high-quality components accentuate the tonal texture.

Class A Stereo Power Amplifier S-05





Versatility

The S-05 offers luxurious functionality befitting a high-end system and can be used in a variety of ways. When paired with the N-05XD network DAC/preamp, the S-05 completes a high-end system with only two components in a minimalist style. The ES Link Analog connection allows you to enjoy a simpler, more refined musical experience without being overwhelmed by the presence of gears. The S-05 can also be linked to the N-05XD for power on/off.

The S-05 can be system-up to a mono-block amplifier using two units. Mode switching supports BTL drive for powerful high output, and bi-amp drive for speakers with separate HF/LF inputs. Build your dream Class-A amplifier system according to the sound quality and characteristics you seek.

* The 3.5mm mono mini plug cable for connection is sold separately. Please prepare a cable of the length appropriate for your environment.

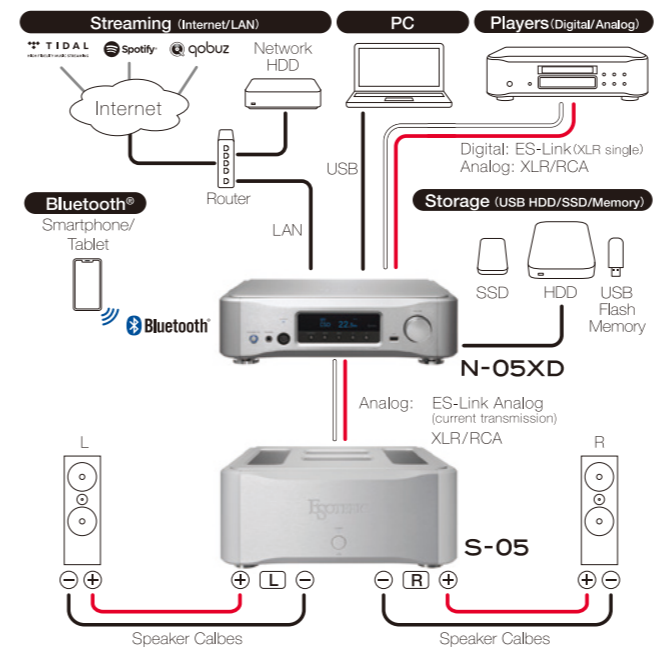

Bi-amp mode

When two S-05 units are deployed and set to "bi-amp mode," the same audio signal is output from both L and R speaker terminals. This means that a single unit can be used as a monaural power amplifier with two speaker outputs. The output power is the same as when one S-05 is deployed in normal stereo mode (30W/8Ω), but as shown in the figure, the HF/LF units of the speaker can be driven by separate power amplifier circuits, enabling a more pure sound from a multi-way speaker system.. This mode is effective when resolution is more important than driving power.

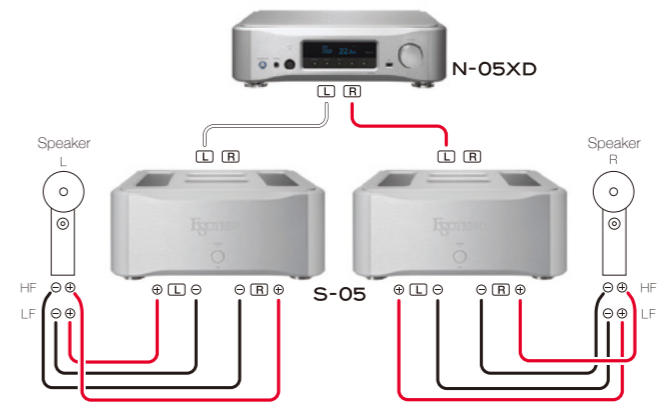

BTL mode

When more driving power is required, such as when the efficiency of the speakers is low, the "BTL mode" deploying two S-05s is recommended. The two built-in amplifier circuits can be bridged to form a high-power 120 W (into 8 ohms) monaural amplifier system. Bridged/balanced amplifier provides a powerful grip and firm drive for the speaker units.

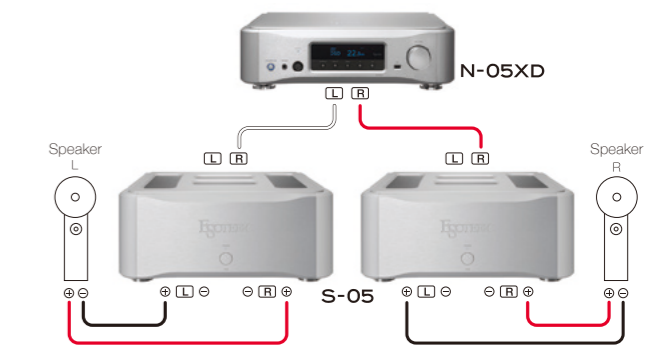



Minimalist High End Style

With the N-05XD and the S-05, a high-end system can be built with a minimum configuration.

With an easy-to-use network as the source, the Master Sound discrete DAC and fully balanced preamplifier circuits inherited from upper models deliver top class sound.

Simple and high-quality system is yours.

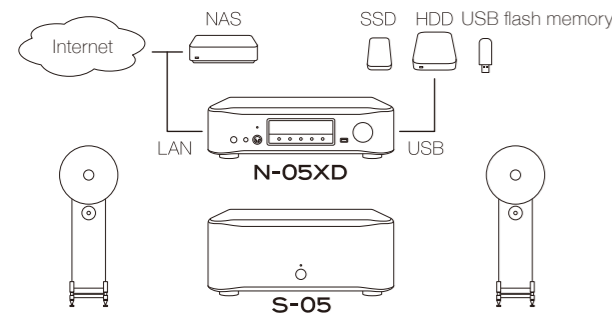

You can connect NAS to the network as a music server. You can also connect USB storage devices such as USB flash drive, USB HDD and SSD to the N-05XD.



Network/DAC

The N-05XD is a perfect unit for those who simply plan to add a network player/discrete DAC unit to your existing audio system.

Once you set the volume off (fixed level) of the N-05XD, it behaves as a pure network player or DAC unit.

The built-in preamplifier circuits perform as a high-quality fixed volume buffer amplifier with fully balanced and dual monaural circuits design supporting pure and powerful sound.

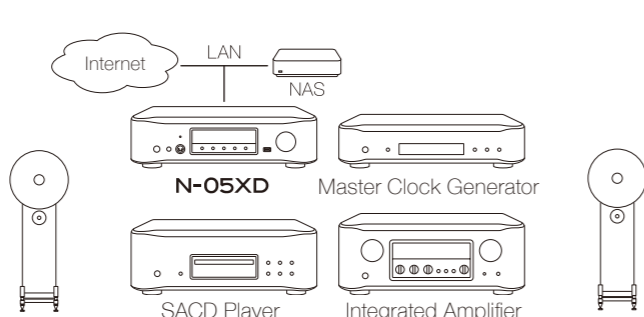

Super Audio CD Transport + DAC

Upgrade your Esoteric digital source equipment like SACD/CD transport and CD player to even higher sound quality and up-to-date unit with a discrete DAC on the N-05XD.

New ways of digital playback from network source and MQA-CD you cannot perform with old models is realized.

With an Esoteric SACD transport, a single XLR cable (ES-Link) allows the system to transmit pure SACD signal to the N-05XD.

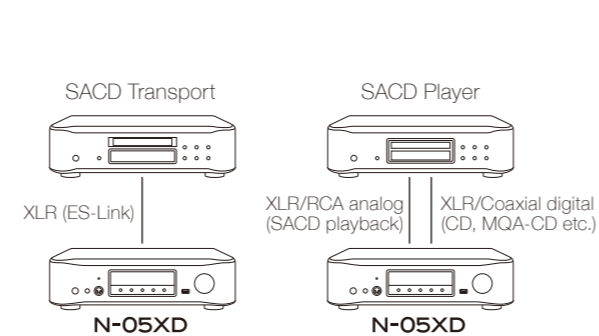

If you prefer to use the N-05XD as a standalone DAC unit, you can simply switch off the network function on the setting menu.



The Ultimate Head-Fi System

For those who needs nothing but a favorite pair of headphones in their life, the N-05XD's network engine allows them to fully enjoy super high quality streaming on their desktop.

Its discrete DAC and fully balanced amplifier circuits deliver original master quality sound, while a built-in Bluetooth® receiver realizes casual listening style with a smartphone.

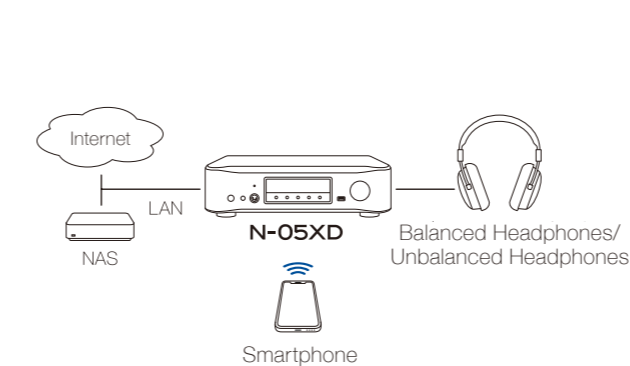

Streaming Player / Roon Client

The N-05XD supports a wide range of streaming platform including Tidal, Spotify, and Qobuz, allowing you to enjoy your music life to the fullest with these subscription services.

The N-05XD also behaves as a USB DAC for PC audio thanks to its USB B port, while supporting Roon Ready. You can use it freely according to your listening environment.

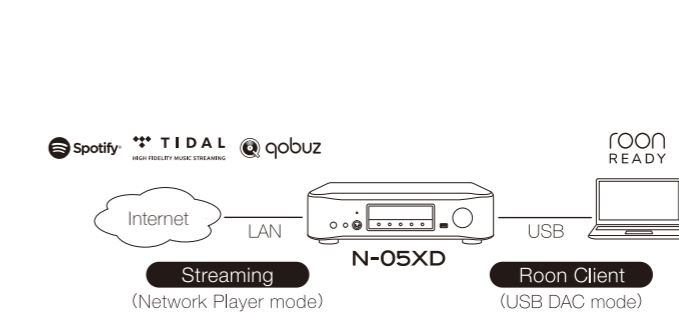

The Ultimate Studio Monitor

The N-05XD is also a perfect unit for professional musicians. With the N-05XD and professional grade active studio monitor speakers, the original master sound is reproduced in home studio.

Enjoy the live sound of your favorite performances or favorite artists in your home. With an ultra precision master clock generator, more professional and high-grade monitoring environment is available.

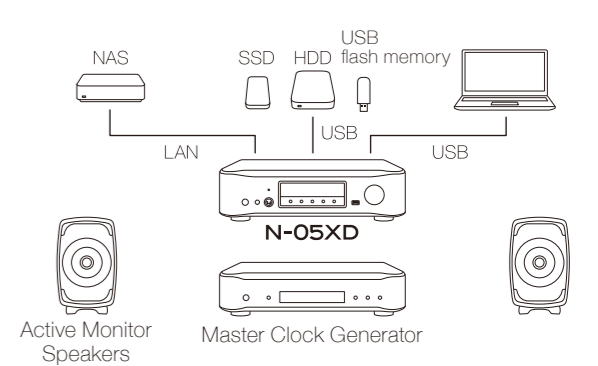



N-05XD Network DAC / Preamp



Digital Audio Inputs: XLR x 1
Coaxial x 2
Optical x 2
USB x 1
Ethernet x 1
USB Drive x 2 (Front, Rear)
Bluetooth®

Analog Audio Inputs: XLR x 1 pair
RCA x 1 pair

Analog Audio Outputs: XLR/ES-Link Analog x 1 pair
ES-Link Analog PRE-OUT x 1 pair
RCA x 1 pair

Clock Input: BNC x 1

Unbalanced Headphone Out: 6.3mm Stereo x 1
(Max Output Power 750mW + 750mW/32Ω)

Balanced Headphone Out: 4-pin XLR x 1
(Max Output Power 1500mW + 1500mW/32Ω)

Frequency Response: 5Hz to 75kHz (-3dB)

S/N Ratio: 105dB (IHF-A)

Total Harmonic Distortion: 0.0015% (1kHz)

Power: 120V AC 60Hz, 220-240V AC 50Hz

Overall Dimensions (W×H×D): 445 x 131 x 377 mm (include protrusions)

Weight: 13.8kg

- Each product is available in two different power supply variations as shown in the chart above. Make sure that the voltage shown on the rear panel matches the AC line voltage in your area.
- The shape of the AC inlet and plug of the supplied power cord depends on the voltage rating and destination country.

Please note that not all models are available in every country. Design and specifications subject to change without notice.
©2023 Esoteric Company. All Rights Reserved. All text, images, graphics and other materials on this brochure are subject to the copyright and other intellectual property rights of Esoteric Company. These materials shall not directly or indirectly be published, reproduced, modified or distributed in any medium. Esoteric is a trademark of TEAC Corporation, registered in the U.S. and other countries. Grandioso is a trademark of TEAC Corporation. All other brand or product names are trademarks or registered trademarks of their respective holders.

ESOTERIC COMPANY

1-47, Ochiai, Tama-shi, Tokyo Japan 206-8530
<https://www.esoteric.jp/en>



S-05 Class-A Stereo Power Amplifier



Rated Output Power: 30 W + 30W (8Ω, Class-A)
60 W + 60W (4Ω)
120W (BTL mode, 8Ω)

Analog Audio Inputs: ES-Link Analog x 1 pair
XLR x 1 pair
RCA x 1 pair

Frequency Response: 5Hz to 100kHz (+0dB, -3dB, 8Ω)

S/N Ratio: 102dB (IHF-A, XKR)

Total Harmonic Distortion: 0.007% (1kHz, 8Ω m 30W)

Compatible Speaker Impedance: 4 to 16Ω
8 to 16Ω (BTL mode)

Gain: 28.5dB

Power: 120V AC 60Hz, 220-240V AC 50Hz

Overall Dimensions (W×H×D): 445 x 191 x 444 mm (include protrusions)

Weight: 30.7kg

Authorized Dealer